



**T2x**  
Wireless Remote Control

**Quick Reference Guide**



**Key Features**

The remarkable T2x is the fifth generation of RTI's renowned T2 remote control platform. The 2.8" color display delivers vivid custom graphics, including two-way feedback with album art, while the perfect selection of soft-touch buttons provide quick access to common tasks.

The T2x comes loaded with the following features and much more:

- Dual RF capability uses 433MHz and 2.4GHz (utilizing Zigbee® technology).
- Integrated 802.11b/g wireless Ethernet.
- Two-way control using 2.4GHz (Zigbee), WiFi and RTI control components.
- Flush mount, edge-to-edge touchscreen.
- Integrated grip sensors keep the remote awake while in use.
- Accelerometer provides instant-on control.

**Product Contents**

Contents within the box include the following items:

- One (1) T2x Remote Control
- One (1) Docking Station
- One (1) International Power Supply Kit (5V, 2A)
- One (1) Quick Reference Guide
- One (1) Firmware Update Notification

**Safety Suggestions**

**Read and Follow Instructions.** Read all safety and operating instructions before operating the unit.

**Retain Instructions.** Keep the safety and operating instructions for future reference.

**Heed Warnings.** Adhere to all warnings on the unit and in the operating instructions.

**Heat.** Keep the unit away from heat sources such as radiators, heat registers, stoves, etc., including amplifiers that produce heat.

**Power Sources.** Use only batteries of the type described in the operating instructions, or as marked on the unit.

**Water and Moisture.** Do not use the unit near water—for example, near a sink, in a wet basement, near a swimming pool, near an open window, etc.

**Object and Liquid Entry.** Do not allow objects to fall or liquids to be spilled into the enclosure through openings.

**Servicing.** Do not attempt any service beyond that described in the operating instructions. Refer all other service needs to qualified service personnel.

**Damage Requiring Service.** The unit should be serviced by qualified service personnel when:

- Objects have fallen or liquid has been spilled into the unit.
- The unit has been exposed to rain.
- The unit does not appear to operate normally or exhibits a marked change in performance.
- The unit has been dropped or the enclosure has been damaged.

**Limited Warranty**

RTI warrants its products for a period of one (1) year (90 days only for included battery packs); or for a period of time compliant with local laws when applicable from the date of purchase from RTI or an authorized RTI distributor.

This warranty may be enforced by the original purchaser and subsequent owners during the warranty period, so long as the original dated sales receipt or other proof of warranty coverage is presented when warranty service is required.

Except as specified below, this warranty covers all defects in material and workmanship in this product. The following are not covered by the warranty:

Damage resulting from:

1. Accident, misuse, abuse, or neglect.
2. Failure to follow instructions contained in this Guide.
3. Repair or attempted repair by anyone other than Remote Technologies Incorporated.
4. Failure to perform recommended periodic maintenance.
5. Causes other than product defects, including lack of skill, competence or experience of user.
6. Shipment of this product (claims must be made to the carrier).
7. Being altered or which the serial number has been defaced, modified or removed.

**Contacting RTI**

For news about the latest updates, new product information, and new accessories, please visit our web site at: [www.rticorp.com](http://www.rticorp.com)  
For general information, you can contact RTI at:

Remote Technologies Incorporated  
5775 12th Avenue East, Suite 180  
Shakopee, MN 55379  
Tel. (952) 253-3100  
Fax (952) 253-3131

**Service & Support**

If you are encountering any problems or have a question about your RTI product, please contact RTI Technical Support for assistance (see the Contacting RTI section of this guide for contact details).

RTI provides technical support by telephone or e-mail. For the highest quality service, please have the following information ready, or provide it in your fax or e-mail.

- Your Name
- Company Name
- Telephone Number
- E-mail Address
- Product model and serial number (if applicable)

If you are having a problem with hardware, please note the equipment in your system, a description of the problem, and any troubleshooting you have already tried.

If you are having a problem with software, please note what version you have installed, the operating system on your PC, a description of the problem, and any troubleshooting you have already tried. If you are calling about a software or programming question or problem, please be at your computer when you place your call. This will considerably speed up the troubleshooting process.

**\*Please do not return products to RTI without return authorization.\***

**Federal Communications Commission Notice**

This equipment has been tested and found to comply with the limits for a Class B digital device, pursuant to Part 15 of the FCC Rules. These limits are designed to provide reasonable protection against harmful interference in a residential installation. Any changes or modifications not expressly approved by the party responsible for compliance could void the user's authority to operate the device.

This equipment generates, uses, and can radiate radio frequency energy and, if not installed and used in accordance with the instructions, may cause harmful interference to radio communications. However, there is no guarantee that interference will not occur in a particular installation.

If this equipment does cause harmful interference to radio or television reception, which can be determined by turning the equipment off and on, the user is encouraged to try to correct the interference by one or more of the following measures:

- Reorient or relocate the receiving antenna.
- Increase the separation between the equipment and the receiver.
- Connect the equipment into an outlet on a circuit different from that to which the receiver is connected.
- Consult the dealer or an experienced radio/TV technician for help.

This device complies with Part 15 of the FCC Rules. Operation is subject to the following two conditions:

1. This device may not cause harmful interference.
2. This device must accept any interference received including interference that may cause undesired operation.



**Contains:**  
FCC ID: MMURTI1500, IC:3166A-1500  
FCC ID: MMURTI1600, IC:3166A-1600

**DECLARATION OF CONFORMITY (DOC)**

The Declaration of Conformity for this product can be found on the RTI website at: [www.rticorp.com/declaration](http://www.rticorp.com/declaration)

## Powering On/Off the T2x

NOTE: During normal operation, powering the T2x off should not be necessary.

### TO POWER THE T2x ON:

- Press and hold the "Backlight" button and the "OK" buttons simultaneously until the remote turns on (approx. 1-2 seconds).

OR

- Place the T2x in the docking station - this will automatically power the unit on. (Docking station does not need to be powered).

### TO POWER THE T2x OFF:

- Press and hold the "Backlight" button and the "OK" buttons simultaneously until the remote turns off (approx. 5 seconds).

## Charging the T2x Battery

### WHEN TO CHARGE THE T2x:

The T2x uses a Lithium-ion rechargeable battery which does not exhibit a memory effect from being charged too often and may be placed into the dock when not in use.

- A low battery icon will illuminate at the top right of the T2x (above the display) when the battery capacity becomes low and a charge cycle is required.

### CHARGING THE T2x:

1. Locate and install the appropriate wall outlet plug on to the power supply.
2. Insert the micro USB end of the power supply cable into the USB port located on the backside of the docking station.
3. Plug the power supply cable into a wall outlet.
4. Gently slide the T2x into the docking station clear plastic alignment sleeve until the remote is seated on to the dock connector.

The "Backlight" button on the bottom of the T2x will illuminate red while charging takes place and change to green once the charge cycle completes.

NOTE: Plugging the T2x docking station into a PC using a USB cable will also charge the T2x.

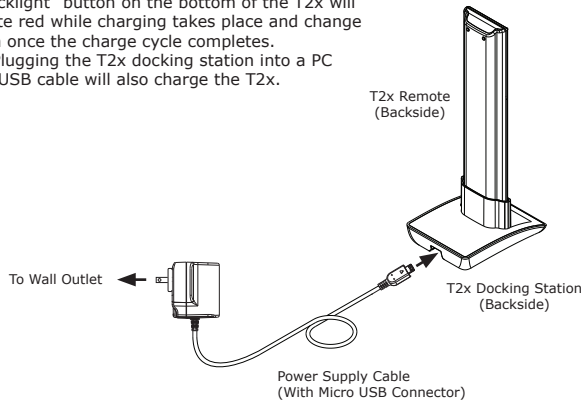

## Replacing the T2x Battery

The following steps for removing the battery door should be performed by an authorized service center or trained installer only.

### REMOVE THE BATTERY DOOR:

1. Gently insert a small paper clip into the battery door latch hole until it stops (see diagram).
2. Tilt the paper clip toward the top of the T2x to release the battery door latch.

### REPLACE BATTERY:

1. Remove two (2) battery bracket screws (Phillips head) and remove bracket.
2. Slide battery out of T2x - pull on plastic tab connected to battery.
3. Slide new battery into T2x - metal contacts inserted first and label facing up.
4. Replace battery bracket and install two (2) screws - in order to align battery bracket properly, get both screws started before tightening fully.
5. Reinstall battery door - first align the wide end of the battery door against the battery door opening, then push the latch end of the door into the T2x until it snaps in place.

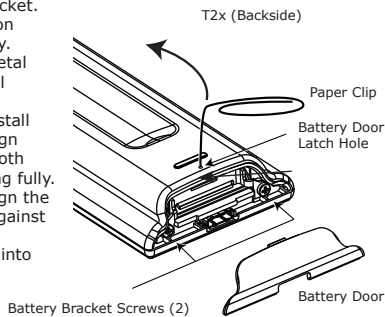

## Programming the T2x

### THE TOUCHSCREEN DISPLAY AND HARD BUTTONS

The T2x touchscreen display and buttons are programmed using the RTI Integration Designer® programming software. Normally the touchscreen is organized into a series of pages containing objects (buttons, text, graphics, etc.) for controlling electronics such as a music server, lighting system or DVD player. Pages will also have programming assigned to the hard buttons that coincide with the device that is being controlled.

### FIRMWARE AND SOFTWARE UPDATES

Please verify that you have the most recent firmware and software installed for this and all RTI products. Authorized RTI dealers can download the latest firmware and Integration Designer from the dealer section of [www.rticorp.com](http://www.rticorp.com).

### INSTALLING FIRMWARE

1. Turn off the T2x - Press and hold the "Backlight" button and the "OK" buttons simultaneously.
2. Connect the T2x dock to a PC using a USB cable (USB A to Micro B).
3. Press and hold the "5-way Joystick" button.
- 4a. Place the T2x into the docking station.

OR

- 4b. Connect the T2x to a PC directly using an RTI programming cable. (Programming cable is included with RTI IRPRO programming kit. Contact RTI customer service or your local distributor to purchase this cable if you already own an IRPRO programming kit).

### UPDATING INTEGRATION DESIGNER PROGRAMMING

RTI's Integration Designer data files can be downloaded to the T2x using the following methods:

- Connect the docking station to a PC using a USB cable (USB A to Micro B) and place the T2x into the docking station.

OR

- Connect an RTI programming cable to the T2x and a PC. (Programming cable is included with RTI IRPRO programming kit. Contact RTI customer service or your local distributor to purchase this cable if you already own an IRPRO programming kit).

OR

- Wirelessly via the local area Ethernet network (LAN). NOTE: Initial programming including network settings will need to take place using the docking station or the RTI programming cable.

### Downloading software/firmware updates via the T2x docking station and USB cable

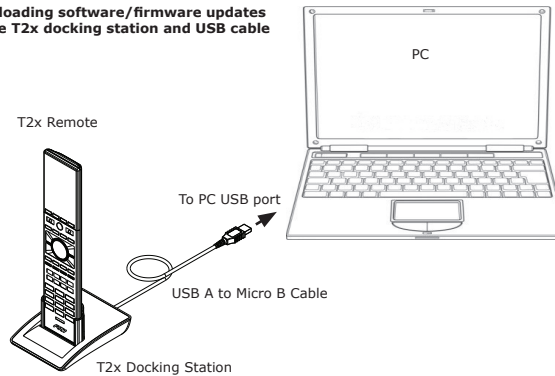

## The T2x Control Panel

The T2x has many settings that can be adjusted directly on the remote through the control panel. Please note that changes made directly in the T2x control panel will be overwritten by changes made in Integration Designer.

### ACCESSING THE CONTROL PANEL

The Control Panel page can be displayed by holding down the "Backlight" button until the page is displayed (approx. 5 seconds).

### ADJUSTABLE SETTINGS

- Backlight Level • Time Out • Tilt Switch • Grip Sensor • Battery
- Sound • Calibrate Touchscreen • Network Information

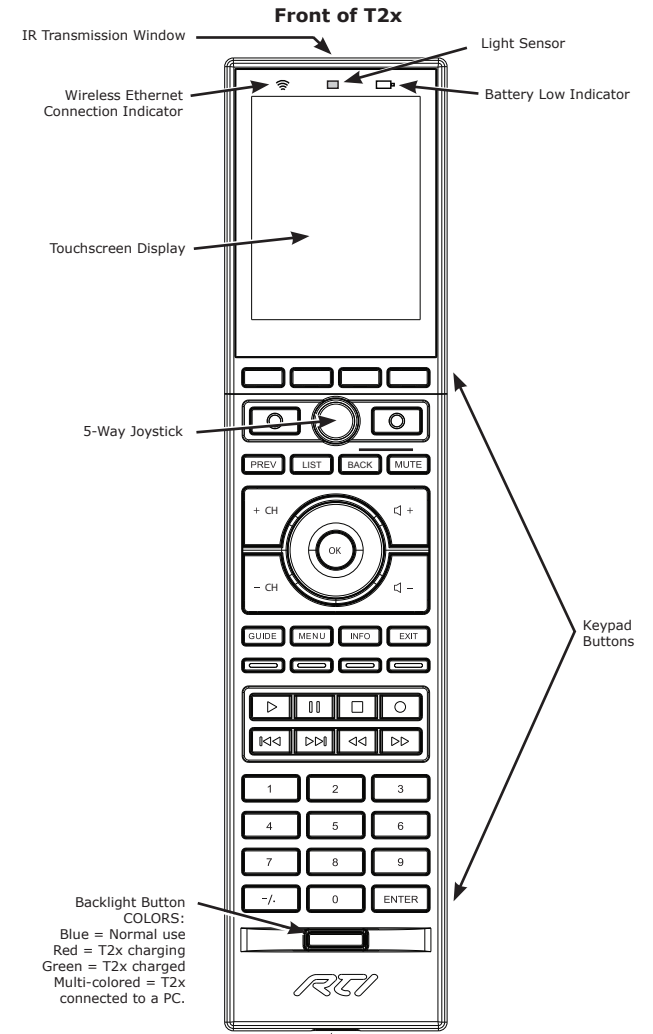

NOTE: The T2x dock connector port is for both charging and programming. It is only compatible with a T2x Docking Station or an RTI programming cable.

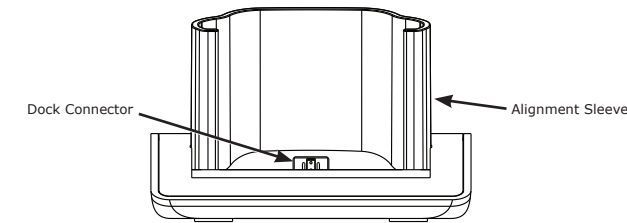

### THE T2x DOCKING STATION

The T2x dock station is used to charge the T2x battery and to download software and firmware updates into the T2x from a PC. The dock has a micro USB jack for connection of the included AC power supply cable or a standard USB A to Micro B cable.